



**HUSKY**<sup>®</sup>  
C O M M E R C I A L

## Display Freezer User Manual



**To ensure safe operation, please read this user manual thoroughly before use.**

© Husky. Husky reserve the right to change specifications at any time without notice.

Images used are for illustration only. Stock not included.





# Welcome to your new Husky

Thank you for buying this Husky commercial freezer. It has been designed and manufactured for many years of trouble-free service.

Operation is very simple, but please take a few minutes to read this user manual. It contains important safety information, and tips to ensure you receive the best possible service from your Husky unit.

Model	Voltage	Refrigerant	Capacity (Litres)	Dimensions without canopy HxWxD (mm)	Weight (kgs)
<b>F14-C-UK-HRN</b>	230v	R290	94	850x584x694	48
<b>F38-C-UK-HRN</b>	230v	R290	271	850x1240x694	71

## CONTENTS

Important Notes.....	3
Safety instructions and warnings.....	3
Before using for the first time.....	4
Troubleshooting.....	5
Operating Instructions.....	6
Defrosting.....	6
Cleaning.....	6
Illustration.....	7
Circuit diagrams.....	7

## All models

### Important Notes

#### **WARNING: RISK OF ELECTRICAL SHOCK HAZARD**

If the power cable is damaged, it must be replaced by a qualified engineer to avoid shock hazard. **DO NOT ATTEMPT TO SERVICE THE ITEM YOURSELF.** Ensure that the unit is properly earthed. Stop using the freezer immediately if electric shock is felt when touching the cabinet.



#### **WARNING: RISK OF FIRE/FLAMMABLE MATERIALS**

This refrigeration unit contains highly flammable refrigerant gases. To prevent leakage, do not tamper with or damage components or pipework. Do not place the unit near naked flames or sources of ignition. Stop using the freezer immediately in the event of accidental damage.



### DISPOSAL OF OLD FREEZERS

**BE SURE TO MAKE ANY LOCKS UNUSABLE. IF POSSIBLE, REMOVE THE DOOR(S) AND DISCARD SEPARATELY.**

**WARNING – CHEMICAL HAZARD: DO NOT ALLOW CHILDREN TO PLAY WITH OLD FREEZERS. CONTACT YOUR LOCAL AUTHORITY FOR PROPER DISPOSAL PROCEDURES.**

Before disposing of an old freezer, please make sure it is switched off and safe. Unplug the freezer and break any locks in order to avoid children becoming trapped.

Please note: the refrigeration system contains gases and refrigerants which require specialist waste disposal. The valuable materials contained in a freezer can be recycled.

Contact your local waste disposal depot for proper disposal of an old freezer and contact your local authority or dealer if you have any questions.

Ensure the pipework of your freezer is not damaged prior to disposal. You can contribute to the environmental awareness by insisting on an appropriate non-polluting method of disposal.

### WEEE COMPLIANCE

Husky freezers are authorised to carry the CE (Conformité Européene) and WEEE (Waste Electrical and Electronic Equipment Directive) symbols.



The WEEE symbol on this freezer indicates that the product must not be disposed of with household waste. To help prevent possible harm to health and the environment, the product must be disposed of by recycling methods authorised as environmentally safe. For more information on how to dispose of this product appropriately, contact your dealer or the recycling department at your local authority.

Husky freezers and their components undergo strict product testing by independent companies to comply with or exceed all applicable local and international regulatory standards.



GB

Technical Support: 01455 555340 (UK)

## SAFETY INSTRUCTIONS & WARNINGS

Before switching on your Husky commercial freezer, read the information in this user manual carefully. The user manual contains important observations relating to the assembly, operation and maintenance of the unit.

Please keep this user manual in a safe place for future reference. If you ever sell this unit, hand this user manual to the new owner.

The manufacturer does not accept responsibility for any damages that may arise due to non-observation of these instructions.

- Do not use the unit if it is damaged. If you are in any doubt, consult an engineer.
- Connection and installation of your Husky unit are to be carried out in strict compliance with the relative instructions in this user manual.
- Make sure there is a suitable power outlet (230 volts, 13 amps outlet) with proper grounding to power the freezer.
- For safety, the unit must be properly earthed in accordance with specifications.
- Always remember to unplug the unit before cleaning. Never unplug this unit by pulling on the power cable. Always grip plug firmly and pull straight out from the socket.
- All electrical repairs must be carried out by a qualified engineer. Inadequate repairs may be dangerous.
- Do not damage any parts of the freezer which carry refrigerant by piercing, perforating, crushing, twisting or scraping. If refrigerant comes into contact with the eyes it may cause serious eye injury.
- Do not obstruct or cover the ventilation grille.
- Do not allow children to play with the unit, or to sit on it or hang onto the door.
- This unit is not intended for use by persons (including children) with reduced physical, sensory or mental capabilities, or lack of experience and knowledge, unless they have been given supervision or instruction concerning use of the unit by a person responsible for their safety.

### BEFORE USING FOR THE FIRST TIME



**IMPORTANT: Before switching the unit on, we recommend you allow it to stand upright for 8 hours. Failure to do this may result in damage to the unit.**

- To ensure correct operation, it is important that the unit is level.
- Before operation, we recommend that the cabinet is cleaned for reasons of hygiene and to remove any residue left from manufacture.
- For good circulation, vents must not be blocked. Keep a minimum of 100mm of clear space around the freezer. Your Husky unit should be placed on flat and firm surface for quieter operation.
- Do not expose the unit to direct sunlight or a heat source such as ovens, radiators, heaters, etc.
- Do not under any circumstances place heated food or beverages in your Husky commercial freezer.
- Do not open the door more often than necessary to lessen the escape of cold air.
- For better air circulation, do not overfill the unit.
- Adjust the thermostat according to the amount of product and the ambient temperature.



**IMPORTANT: This appliance is intended to operate in a climate where the maximum temperature is 30 degrees Celsius and the humidity does not exceed 55%.**



## Troubleshooting

Before calling Technical Support, please check the following points; you may be able to solve any problem yourself.

Problem	Solution
The sound of flowing liquid may be heard.	This is the refrigerant circulating and is part of normal operation.
There is frost on the glass lid.	A little frost develops if the ambient humidity is high. Wipe away with a soft cloth.
The compressor cannot be heard but the freezer inner temperature reads normally.	This is part of normal operation. High levels of insulation means that the compressor may not need to operate for long periods.
Compressor does not work.	<ol style="list-style-type: none"> <li>1. Check the power cable is connected and the socket is switched on.</li> <li>2. Check the fuse and replace with a fuse of a similar rating if necessary.</li> <li>3. Check the thermostat is on the correct setting.</li> </ol>
The unit is excessively noisy.	Check the floor is level and the unit is securely positioned.
The compressor may be heard working constantly.	<p>If the temperature inside is too high, this constant running of the compressor may be explained by:</p> <ol style="list-style-type: none"> <li>1. Warm items being placed into the unit. Ensure warm items are never placed into the unit.</li> <li>2. The freezer lid not being closed properly. Always ensure the lid is closed securely.</li> <li>3. A build-up of ice on the evaporator. Defrost the freezer regularly.</li> </ol>
	<p>If the temperature inside is correct, then this constant running may be due to:</p> <ol style="list-style-type: none"> <li>1. The ambient temperature is too high. If possible try to move the unit to a cooler location, or out of direct sunlight.</li> <li>2. The thermostat is set too low. Check and adjust as necessary.</li> <li>3. The thermostat is not working correctly. Refer to an engineer.</li> </ol>

## F14-C-UK-HRN, F38-C-UK-HRN

### Operating Instructions

Before stocking the freezer with frozen food, the unit must pull down to normal operating temperature. In Summer this may take up to six hours.

To switch the unit on, connect the unit to a 230v mains outlet and press the rocker switch to the on position. The green 'Power On' lamp will illuminate.

To adjust the temperature due to the ambient store temperature or your stock requirements, insert a flat-head screwdriver into the slotted brass screw located on the control panel on the right of the freezer. The screw is graduated 1-7, with 7 being the coldest setting, i.e. turn the screw clockwise and the temperature inside will go down. Turn the screw anti-clockwise and the temperature inside will go up.

The red light indicates that the compressor is working.

The green light indicates that power is connected.

Turning the screw anti-clockwise to "0" means power will be disconnected.

Do not turn the screw clockwise from "7" to "0".

- Notes:
1. Never put warm or hot foods directly into the freezer
  2. Do not exceed the load line
  3. For maximum efficiency, stock should be arranged to allow good air circulation.

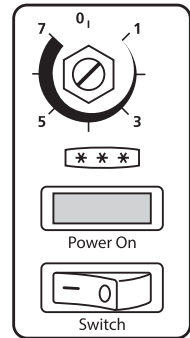

**Control panel**

### DEFROSTING

Remove any stock to a suitable back-up freezer. Switch your Husky freezer off and disconnect the plug from the mains socket. Remove the round white plastic drain plug (on the floor of the interior of the unit) and place a tray under the drain hole to collect melt water. Empty the tray regularly.

Allow any ice to melt naturally. DO NOT use boiling water, corrosive detergents, abrasive scourers, wire brushes, electric heaters or sharp or metal objects to remove ice or hasten defrosting. These may damage the unit and void the warranty.

When all the ice is clear and waste water removed, refer to 'Cleaning' below to sanitise and dry the unit thoroughly. The freezer may then be reconnected and switched on. Wait at least two hours before returning any stock to the unit.

### CLEANING

If the condenser coil is not cleaned quarterly, the energy efficiency of the appliance will decrease significantly, and it will reduce the life of the appliance." Use a vacuum cleaner fitted with a soft brush attachment to remove dust carefully from the condenser, the components and grilles.

The external and internal surfaces of the unit should be cleaned regularly. Switch the unit off and disconnect the plug from the mains socket. Clean the external and internal surfaces of the unit with a mild soap solution, then wipe dry. Do NOT use cleansers containing chlorine or other harsh cleansing agents, as these can damage the stainless steel surfaces and components. Use mild soapy water to clean the gasket and seals.

## SERVICE

The cooling system is a hermetically sealed circuit and does not require any maintenance other than regular cleaning (see above).

If the unit fails to work, first check the power supply. If you cannot locate the reason for the failure, please contact your supplier, stating the model and serial number of the cabinet. You may find this information on the rating plate, which is affixed either on an inside wall or on the back of the unit.

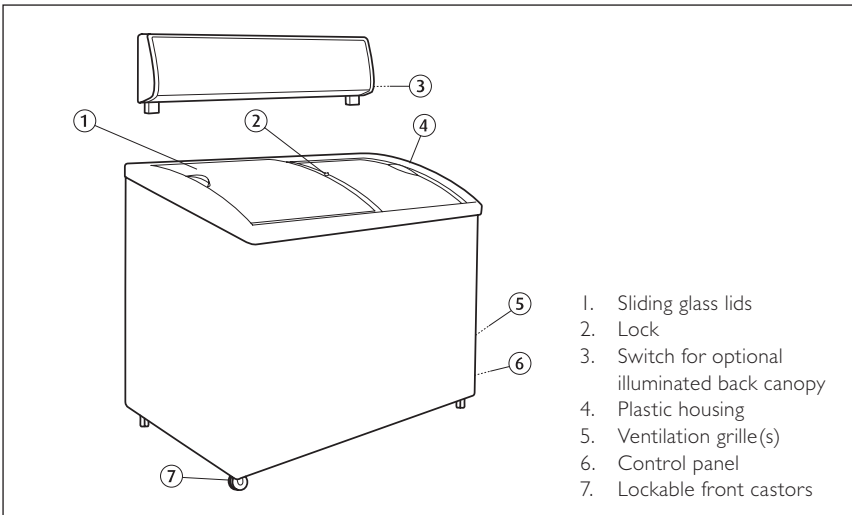

## Circuit Diagrams

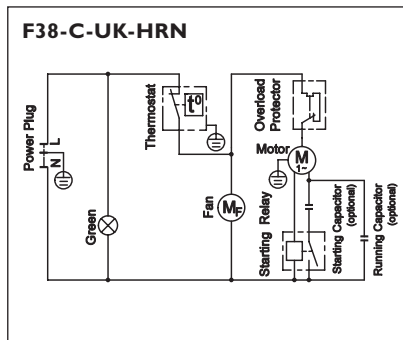
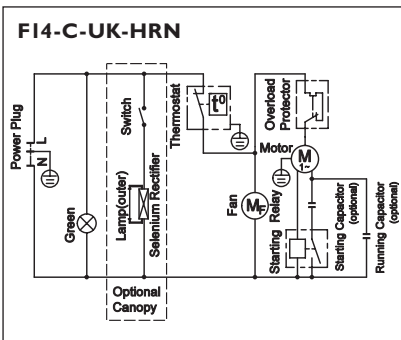



Welcome to Husky, the home of smart refrigeration. We are a leading global refrigeration specialist with over 25 years experience in quality refrigeration for convenience and hospitality professionals, and we have a great range of chillers for the home too. You'll find Husky products all over the world, so whatever your requirements we're sure to have a good looking energy-efficient model that's perfect for you.

**HUSKY**<sup>®</sup>  
C O M M E R C I A L

[www.husky.co.uk](http://www.husky.co.uk)

**HELPLINE/TECHNICAL SUPPORT**

Tel: 01455 555340 (Monday to Friday 0900 – 1700).

Email: [service@husky.co.uk](mailto:service@husky.co.uk)

**SALES**

Tel: 01455 555340 (Monday to Friday 0900 – 1700).

Email: [sales@husky.co.uk](mailto:sales@husky.co.uk)

**OUT-OF-WARRANTY SPARES**

Email: [parts@husky.co.uk](mailto:parts@husky.co.uk)

290621

