

User manual – Solid Lid Chest Freezer



To ensure safe operation, please read this user manual thoroughly before use.

© 2018 Husky. Husky reserve the right to change specifications at any time without notice.

Images used are for illustration only. Stock not included.



Welcome to your new Husky

Thank you for buying this Husky commercial freezer. It has been designed and manufactured for many years of trouble-free service.

Operation is very simple, but please take a few minutes to read this user manual. It contains important safety information, and tips to ensure you receive the best possible service from your Husky unit.

Model	Voltage	Refrigerant	Capacity (Litres)	Dimensions HxWxD (mm)	Weight (kgs)
F400-SD-UK-HT	230v	R600a	339	845x1395x650	67
F500-SD-UK-HT	230v	R600a	462	845x1795x650	82
F600-SD-UK-HT	230v	R290	523	845x1995x650	87

CONTENTS

Important Notes.....	3
Warning! Risk of electrical shock hazard.....	3
Disposal of old refrigerators.....	3
WEEE Compliance.....	3
Safety instructions and warnings.....	3
Before using for the first time.....	4
Troubleshooting.....	5
F400-SD-UK-HT, F500-SD-UK-HT & F600-SD-UK-HT.....	6
Operating Instructions.....	6
Illustration.....	7
Circuit diagrams.....	7

All models

Important Notes

WARNING: RISK OF ELECTRICAL SHOCK HAZARD

USERS IN EUROPE: This refrigeration unit must be earthed.

If the power cable is damaged, it must be replaced by a qualified engineer to avoid shock hazard. **DO NOT ATTEMPT TO SERVICE THE ITEM YOURSELF.** Ensure that the unit is properly earthed. Stop using the unit immediately if electric shock is felt when touching the cabinet.



DISPOSAL OF OLD REFRIGERATORS

BE SURE TO MAKE ANY LOCKS UNUSABLE. IF POSSIBLE, REMOVE THE DOOR(S) AND DISCARD SEPARATELY.

WARNING – CHEMICAL HAZARD: DO NOT ALLOW CHILDREN TO PLAY WITH OLD REFRIGERATORS. CONTACT YOUR LOCAL AUTHORITY FOR PROPER DISPOSAL PROCEDURES.

Before disposing of an old refrigerator, please make sure it is switched off and safe. Unplug the refrigerator and break any locks in order to avoid children becoming trapped.

Please note: the refrigeration system contains gases and refrigerants which require specialist waste disposal. The valuable materials contained in a refrigerator can be recycled.

Contact your local waste disposal depot for proper disposal of an old refrigerator and contact your local authority or dealer if you have any questions.

Ensure the pipework of your refrigerator is not damaged prior to disposal. You can contribute to the environmental awareness by insisting on an appropriate non-polluting method of disposal.

WEEE COMPLIANCE

Husky freezers are authorised to carry the CE (Conformité Européene) and WEEE (Waste Electrical and Electronic Equipment Directive) symbols.

The WEEE symbol on this unit indicates that the product must not be disposed of with household waste. To help prevent possible harm to health and the environment, the product must be disposed of by recycling methods authorised as environmentally safe. For more information on how to dispose of this product appropriately, contact your dealer or the recycling department at your local authority. Husky freezers and their components undergo strict product testing by independent companies to comply or exceed all applicable local and international regulatory standards.



SAFETY INSTRUCTIONS & WARNINGS

Before switching on your Husky commercial freezer, read the information in this user manual carefully. The user manual contains important observations relating to the assembly, operation and maintenance of the unit.

Please keep this user manual in a safe place for future reference. If you ever sell this unit, hand this user manual to the new owner.

The manufacturer does not accept responsibility for any damages that may arise due to non-observation of these instructions.

- Do not use the unit if it is damaged. If you are in any doubt, consult an engineer.
- Connection and installation of your Husky unit are to be carried out in strict compliance with the relative instructions in this user manual.
- Make sure there is a suitable power outlet (230 volts, 13 amps outlet) with proper grounding to power the freezer.
- For safety, the unit must be properly earthed in accordance with specifications.
- Always remember to unplug the unit before cleaning. Never unplug this unit by pulling on the power cable. Always grip plug firmly and pull straight out from the socket.
- All electrical repairs must be carried out by a qualified engineer. Inadequate repairs may be dangerous.
- Do not damage any parts of the unit which carry refrigerant by piercing, perforating, crushing, twisting or scraping. If refrigerant comes into contact with the eyes it may cause serious eye injury.
- Do not obstruct or cover the ventilation grille.
- Do not allow children to play with the unit, or to sit on it.
- This unit is not intended for use by persons (including children) with reduced physical, sensory or mental capabilities, or lack of experience and knowledge, unless they have been given supervision or instruction concerning use of the unit by a person responsible for their safety.

BEFORE USING FOR THE FIRST TIME



IMPORTANT: Before switching the unit on, we recommend you allow it to stand upright for 8 hours. Failure to do this may result in damage to the unit.

- Remove the wooden pallet and the packing.
- To ensure correct operation, it is important that the unit is level. Use a spirit level to check.
- Before operation, we recommend that the cabinet is cleaned for reasons of hygiene and to remove any residue left from manufacture.
- For good circulation, vents must not be blocked. Keep a minimum of 150mm of clear space around the freezer. Your Husky unit should be placed on flat and firm surface for quieter operation.
- Do not expose the unit to direct sunlight or a heat source such as ovens, radiators, heaters, etc.
- Do not under any circumstances place heated food or beverages in your Husky commercial freezer.
- Do not open the sliding glass doors more often than necessary to lessen the escape of cold air.
- For better air circulation, do not overfill the unit.
- Adjust the thermostat according to the amount of product and the ambient temperature.

Troubleshooting

Before calling Technical Support, please check the following points; you may be able to solve any problem yourself.

Problem	Solution
The sound of flowing liquid may be heard.	This is the refrigerant circulating and is part of normal operation.
There is frost on the unit.	A little frost develops if the ambient humidity is high. Wipe away with a soft cloth.
The compressor cannot be heard but the freezer inner temperature reads normally.	This is part of normal operation. High levels of insulation means that the compressor may not need to operate for long periods.
Compressor does not work.	<ol style="list-style-type: none"> 1. Check the power cable is connected and the socket is switched on. 2. Check the fuse and replace with a fuse of a similar rating if necessary. 3. Check the power switch is in the ON position and the thermostat is on the correct setting.
The unit is excessively noisy.	Check the floor is level and the unit is securely positioned.
The compressor may be heard working constantly.	<p>If the temperature inside is too high, this constant running of the compressor may be explained by:</p> <ol style="list-style-type: none"> 1. Warm items being placed into the unit. Ensure warm items are never placed into the unit. 2. The doors are not being closed properly. Always ensure the doors are closed securely. 3. A build-up of ice on the evaporator. Defrost the freezer regularly.
	<p>If the temperature inside is correct, then this constant running may be due to:</p> <ol style="list-style-type: none"> 1. The ambient temperature is too high. If possible try to move the unit to a cooler location, or out of direct sunlight. 2. The thermostat is set too low. Check and adjust as necessary. 3. The thermostat is not working correctly. Refer to an engineer.

F400-SD-UK-HT, F500-SD-UK-HT & F600-SD-UK-HT

Operating Instructions

TO ADJUST THE TEMPERATURE

Connect the freezer to a power outlet and switch on at the socket. Wait at least two hours before placing stock in the unit.

The thermostat has been pre-set, and in most cases it is not necessary to adjust the settings. When the unit is operating normally, the display will show the current temperature.

If temperature adjustment is required, the temperature control knob may be found on the control panel at the bottom right of the freezer (see Fig. 4 on page 7).

- To lower the internal temperature of the freezer, turn the knob clockwise.
- To raise the internal temperature of the freezer, turn the knob anti-clockwise.

If the knob is turned to its coldest setting, the compressor will run constantly. This is not recommended due to increased wear on parts and higher energy consumption.

DEFROSTING

Remove any stock to a suitable back-up freezer. Switch your Husky chest freezer off and disconnect the plug from the mains socket. Remove the drain plug (see Fig. 2 on page 7) and place a tray under the drain to collect melt water. Empty the tray regularly.

Allow any ice to melt naturally. DO NOT use boiling water, corrosive detergents, abrasive scourers, wire brushes, electric heaters or sharp or metal objects to remove ice or hasten defrosting. These may damage the unit and void the warranty.

When all the ice is clear and waste water removed, refer to 'Cleaning' below to sanitise and dry the unit thoroughly. The freezer may then be reconnected and switched on. Wait at least two hours before returning any stock to the unit.

CLEANING

The condenser and the compressor compartment MUST be cleaned quarterly. Use a vacuum cleaner fitted with a soft brush attachment to remove dust carefully from the condenser, the components and grilles.

The external and internal surfaces of the unit should be cleaned regularly. Switch the unit off and disconnect the plug from the mains socket. Clean the external and internal surfaces of the unit with a mild soap solution, then wipe dry. Do NOT use cleansers containing chlorine or other harsh cleansing agents, as these can damage the stainless steel surfaces and components. Use mild soapy water to clean the gasket and seals.

GETTING SERVICE ASSISTANCE

The cooling system is a hermetically sealed circuit and does not require any maintenance other than regular cleaning (see 'Cleaning').

If the unit fails to work, first check the power supply. If you cannot locate the reason for the failure, please contact your supplier, stating the model and serial number of the cabinet. You may find this information on the rating plate, which is affixed inside the unit on the top right-hand interior wall.

(Model F500-SD-UK-HT pictured)

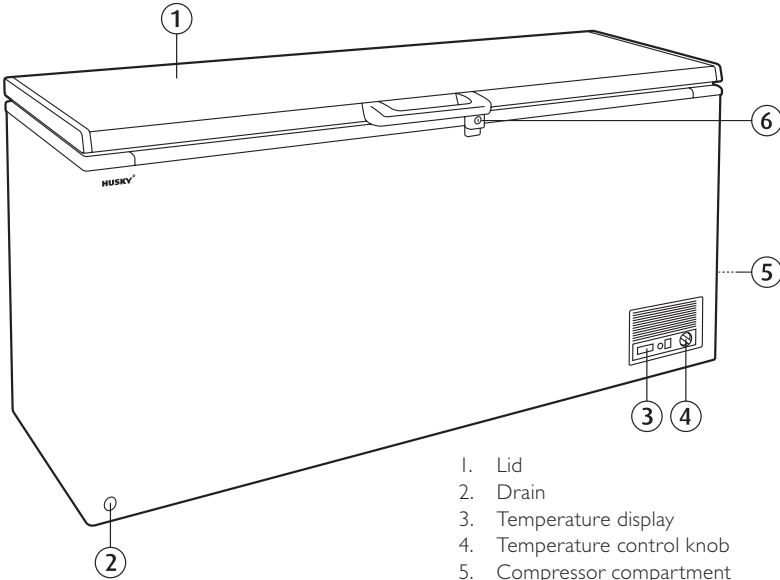

1. Lid
2. Drain
3. Temperature display
4. Temperature control knob
5. Compressor compartment (behind grille)
6. Locking handle

Circuit Diagram

F400-SD-UK-HT, F500-SD-UK-HT & F600-SD-UK-HT

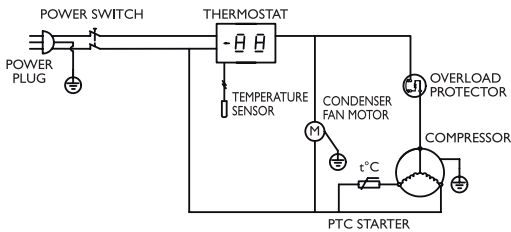



Welcome to Husky, the home of smart refrigeration. We are a leading global refrigeration specialist with over 25 years experience in commercial refrigeration for convenience and hospitality professionals. Whatever your requirements, we're sure to have a good looking energy-efficient model that's perfect for you.

HUSKY[®]
C O M M E R C I A L

www.husky.co.uk

HELPLINE/TECHNICAL SUPPORT

Tel: 01455 555340 (Monday to Friday 0900 – 1700).

Email: service@husky.co.uk

SALES

Tel: 01455 555340 (Monday to Friday 0900 – 1700).

Email: sales@husky.co.uk

OUT-OF-WARRANTY SPARES

Email: service@husky.co.uk